

1	2	3	4	5	6	7	8				
THIS DRAWING AND THE DATA DISCLOSED HEREIN OR HEREWITH IS NOT TO BE REPRODUCED USED OR DISCLOSED IN WHOLE OR IN PART TO ANYONE WITHOUT THE PERMISSION OF JESS-LINK PRODUCTS CO.,LTD.(JPC)				CUSTOMER DRAWING DRWC-011840		REV.	ECN NO.	DESCRIPTION	MDF'D	APP'D	DATE
						01		INITIAL DESIGN	Veero	Venson	08/06/2024
						02					
						03					

A  
B  
C  
D  
E  
F

A  
B  
C  
D  
E  
F

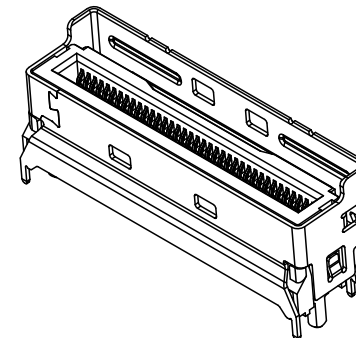
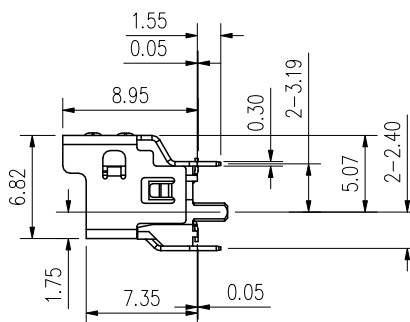
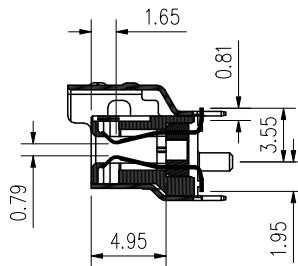
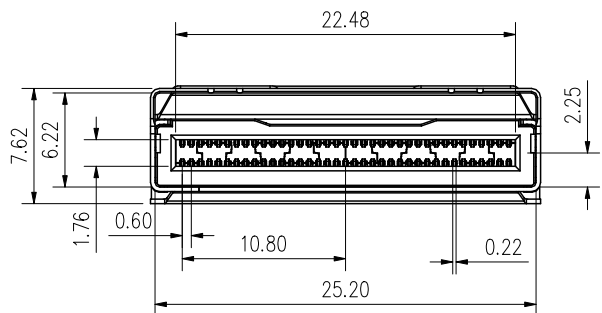
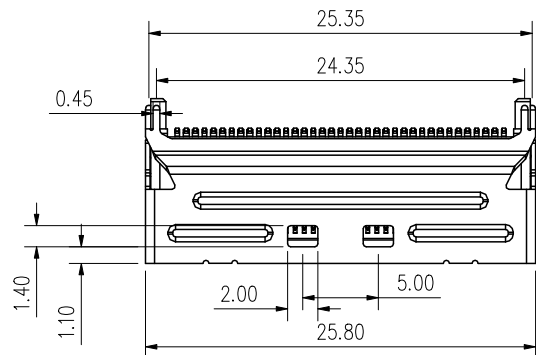
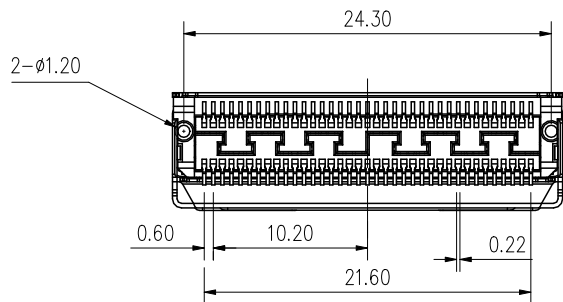

NOTE:

- DATE CODE: YYWWD  
YY=YEAR OF MANUFACTURE  
WW=WEEK OF MANUFACTURE
- PACKAGE: TAPE & REEL
- PRODUCT SPEC REFER TO DSPC-002392
- P/N: MATRIX:

P/N: P 9 4 7 B 0 7 4 4 3 X X - 0  
 MCI0 8X RECEPTACLE  
 POS 074: 74PIN  
 4: STRAIGHT, RECEPTACLE  
 PACKAGE  
 2 : TAPE & REEL WITH CAP  
 3 : TAPE & REEL W/O CAP  
 SHELL AND POST LENGTH  
 0: SHELL 1.5mm,POST 2.0mm  
 1: SHELL 2.2mm,POST 2.0mm  
 2: SHELL 3.0mm,POST 2.0mm  
 3: SHELL 4.2mm,POST 2.0mm  
 PLATING  
 3: CONTACT AREA: GOLD PLATING 30u"MIN  
 SOLDER AREA :GOLD FLASH  
 UNDER PLATING:NICKEL PLATED 50u"MIN OVER ALL

RoHS COMPLIANT	Unit: mm(inch)	PROJECTION	<b>JPC connectivity</b>	
	GENERAL TOLERANCES: (UNLESS SPECIFIED)	D.R. 08/06/2024		
	0 = ±1 (0.039)	Veero	TITLE	PD./FILE NO.
	0.0 = ±1.5 (0.02)	CH.K 08/06/2024	MCI0 X8 VERTICAL RECEPTACLE	XXXXXXXXXX
0.00 = ±.3 (0.012)	Brady	PITCH 0.6 SMT TYPE.	X-XXXX	
0.000 = ±.15 (0.006)	APV.D 08/06/2024	SCALE	SIZE	PART NO.
0° = ± 2°	Venson	1:1	A4	P947B07443XX-0
0.0° = ± 1°				REV. 01
				SHEET 1 OF 3

2 3 4 5 6 7 8

1	2	3	4	5	6	7	8				
THIS DRAWING AND THE DATA DISCLOSED HEREIN OR HEREWITH IS NOT TO BE REPRODUCED USED OR DISCLOSED IN WHOLE OR IN PART TO ANYONE WITHOUT THE PERMISSION OF JESS-LINK PRODUCTS CO.,LTD.(JPC)				CUSTOMER DRAWING DRWC-011840		REV.	ECN NO.	DESCRIPTION	MDF'D	APP'D	DATE
						01		INITIAL DESIGN	Veera	Venson	08/06/2024
						02					
						03					

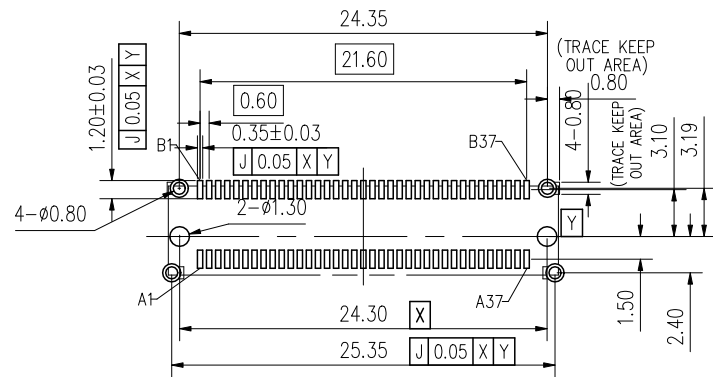

TOLERANCE: ±0.05  
RECOMMENDED P.C.B. Layout  
TOP VIEW

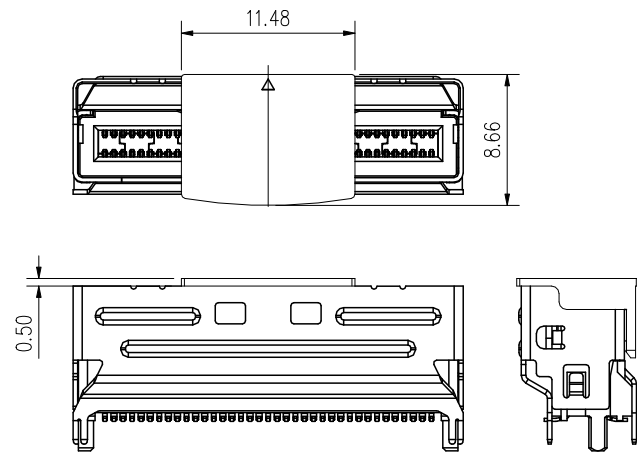

PICK AND PLACE AREA

<b>RoHS COMPLIANT</b>	Unit: mm(inch)	PROJECTION 	<b>JPC connectivity</b>		
	GENERAL TOLERANCES: (UNLESS SPECIFIED)	D.R. 08/06/2024 Veera			TITLE MCIO X8 VERTICAL RECEPTACLE PITCH 0.6 SMT TYPE.
	0 = ±1 (0.039)	CH.K 08/06/2024 Brady	SCALE	SIZE	REV. 01
	0.0 = ±.5 (0.02)	APV.D 08/06/2024 Venson	1:1	A4	SHEET 2 OF 3
0.000 = ±.15 (0.006)			PART NO. P947B07443XX-0		
0° = ± 2°					
0.0° = ± 1°					

1	2	3	4	5	6	7	8				
THIS DRAWING AND THE DATA DISCLOSED HEREIN OR HEREWITH IS NOT TO BE REPRODUCED USED OR DISCLOSED IN WHOLE OR IN PART TO ANYONE WITHOUT THE PERMISSION OF JESS-LINK PRODUCTS CO.,LTD.(JPC)				CUSTOMER DRAWING DRWC-011840		REV.	ECN NO.	DESCRIPTION	MDF'D	APP'D	DATE
						01		INITIAL DESIGN	Veera	Venson	08/06/2024
						02					
						03					

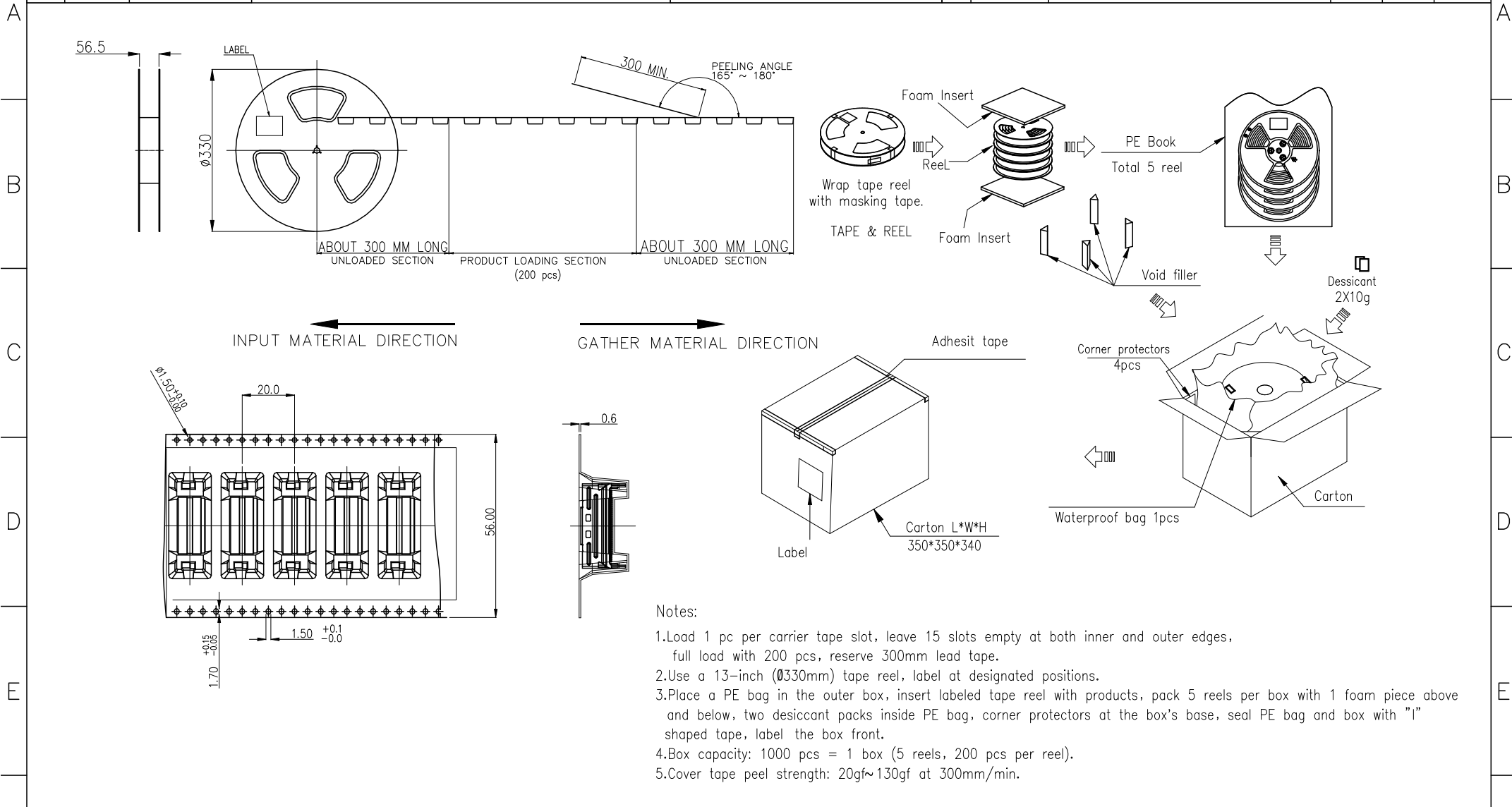

Notes:

1. Load 1 pc per carrier tape slot, leave 15 slots empty at both inner and outer edges, full load with 200 pcs, reserve 300mm lead tape.
2. Use a 13-inch (330mm) tape reel, label at designated positions.
3. Place a PE bag in the outer box, insert labeled tape reel with products, pack 5 reels per box with 1 foam piece above and below, two desiccant packs inside PE bag, corner protectors at the box's base, seal PE bag and box with "I" shaped tape, label the box front.
4. Box capacity: 1000 pcs = 1 box (5 reels, 200 pcs per reel).
5. Cover tape peel strength: 20gf~130gf at 300mm/min.

RoHS COMPLIANT	Unit: mm(inch)	PROJECTION	<b>JPC connectivity</b>		
	GENERAL TOLERANCES: (UNLESS SPECIFIED)	D.R. 08/06/2024			TITLE
	0 = ±1 (0.039)	Veera	MICIO X8 VERTICAL RECEPTACLE	PD./FILE NO. XXXXXXXXX	
	0.0 = ±5 (0.02)	CH.K 08/06/2024	PITCH 0.6 SMT TYPE.	X-XXXX	
0.00 = ±3 (0.012)	Brady	SCALE	SIZE	PART NO.	REV. 01
0.000 = ±15 (0.006)	APV.D 08/06/2024	1:1	A4	P947B07443XX-0	SHEET 3 OF 3
0° = ±2'	Venson				
0.0° = ±1'					